



Wall Lining Systems

www.speedlinedrywall.co.uk

REVISED
04/2024

Wall Lining Systems

INTRODUCING WALL LINING SYSTEMS

Speedline offers a full range of Metal Frame Wall Lining Systems for use in commercial, education, health & domestic situations. The following section provides details of system applications as well as best practice construction guidance.

Contact the Speedline Technical team for advice and support on your project:

enquiries@speedlinedrywall.co.uk

Contents

Speedline Wall Liner System	96
Speedline Independent Wall Lining System	102
Speedline Direct Bond System	106

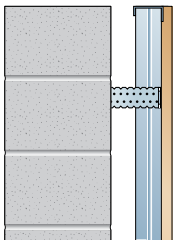

WALL LINING SYSTEMS

SPEEDLINE WALL LINER SYSTEM

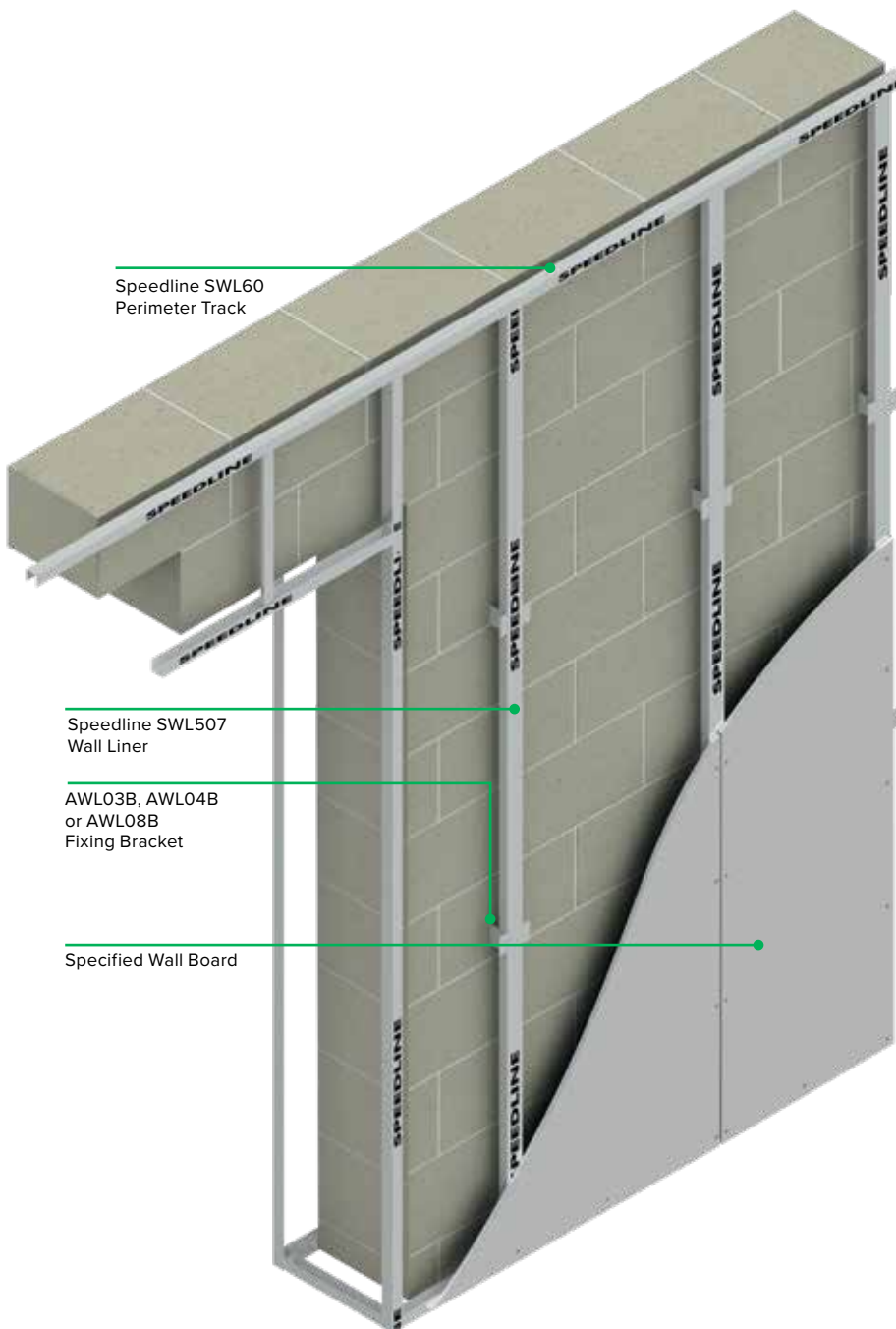

Speedline SWL60
Perimeter Track

Speedline SWL507
Wall Liner

AWL03B, AWL04B
or AWL08B
Fixing Bracket

Specified Wall Board

Benefits

A completely dry system using secure mechanical fixings

- Services can be accommodated within the cavity.
- Can be used to improve sound insulation properties of the substrate.
- With the addition of Speedline Thermal Laminates thermal performance of the substrate can be improved.
- Can be used where plaster or Direct Bond systems are not suitable.
- Provides a flat, level surface whilst dealing with background irregularities.

Speedline Wall Liner System is suitable for internal use in all commercial and domestic applications.

It can be used to provide a lining onto most masonry backgrounds, uneven walls and for concealing services within the cavity. Cavities from 25mm up to 180mm can be formed using appropriate fixing brackets.

Prior to installing Speedline Wall Liner System within older buildings, ensure the substrate is sound and free of any damp.

Sectors

- Student Accommodation
- Hotels
- Healthcare
- Education
- RMI
- Residential
- Commercial

WALL LINING SYSTEMS

SPEEDLINE WALL LINER SYSTEM

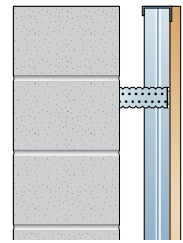



3

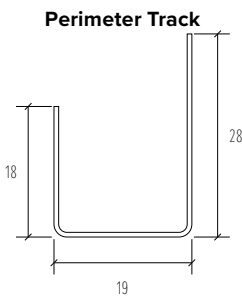
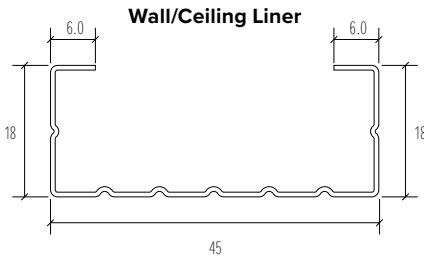

SPEEDLINE WALL LINER SYSTEM



SPEEDLINE WALL LINER SYSTEM

	Product Code	Product Description	Nominal Gauge (mm)	Height (mm)	Width (mm)	Stock Lengths (Metre)	Weight per Length (Kgs)
	SWL507	Speedline Wall & Ceiling Liner	0.5	18	45	2.40	0.83
						2.70	0.93
						3.00	1.04
						3.60	1.25
	SWL60	Speedline Wall & Ceiling Perimeter Track	0.5	18/28	19	3.00	0.73

SPEEDLINE ACCESSORIES (WALL LINER SYSTEM)

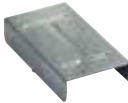
	Product Code	Product Description	Leg Length (mm)	Weight per Box (Kgs)
	AWL03B	Fixing Bracket	75	3.70
	AWL04B	Fixing Bracket	125	5.60
	AWL08B	Fixing Bracket	175	7.50
	AWL05B	Wall/Ceiling Liner Connector		1.35

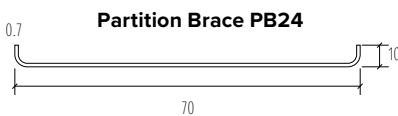
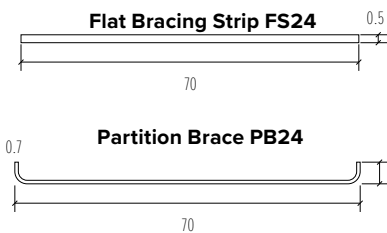

SPEEDLINE FLAT BRACING STRIP & PARTITION BRACE

Product Code	Product Description	Width (mm)	Nominal Gauge (mm)	Height (mm)	Stock Lengths (Metre)	Weight per Length (Kgs)
FS24	Flat Bracing Strip	70	0.5		2.40	0.66
PB24	Partition Brace	70	0.7	10	2.40	1.09

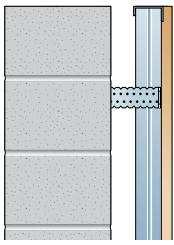

WALL LINING SYSTEMS

SPEEDLINE WALL LINER SYSTEM

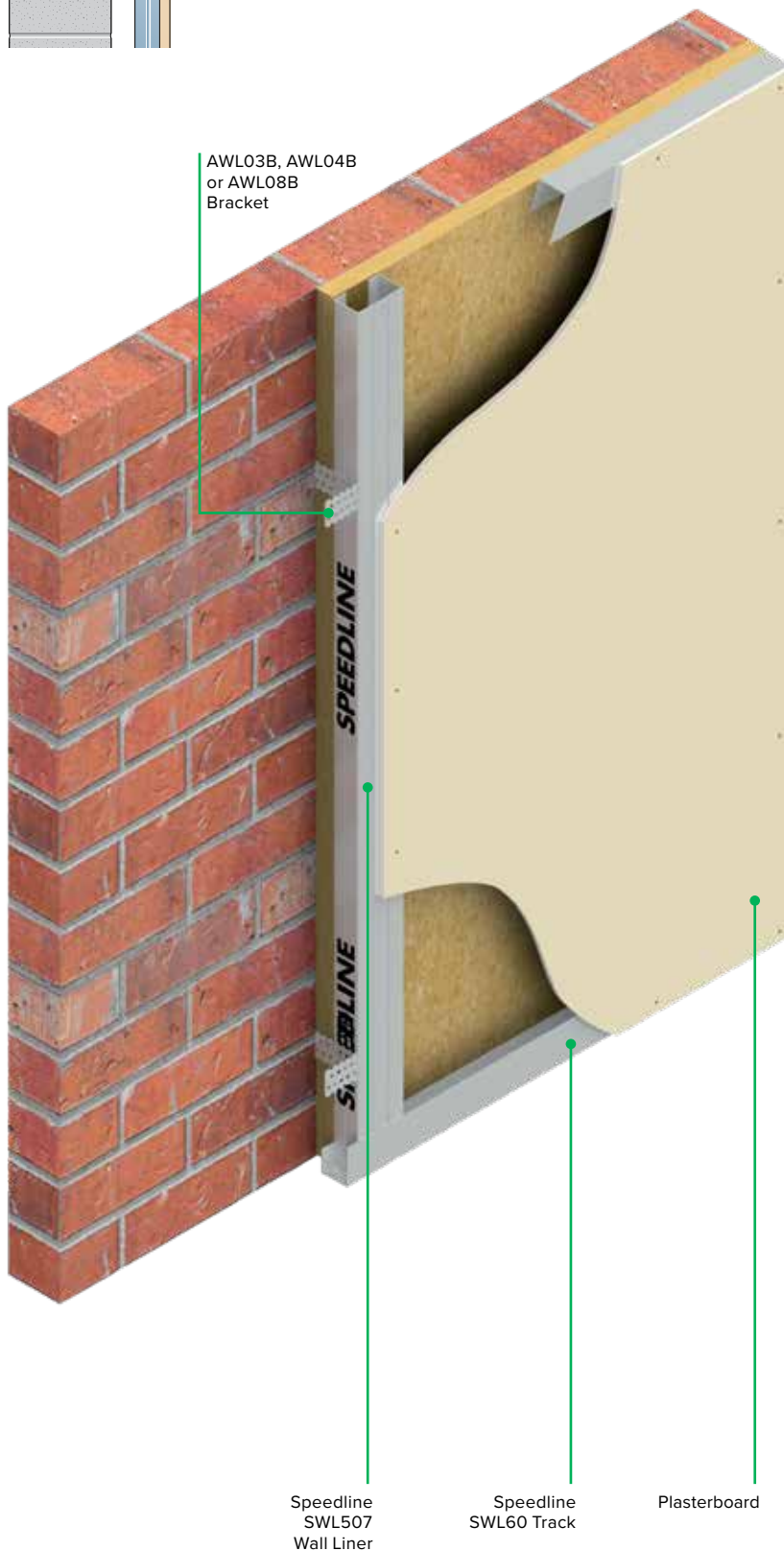

Construction

Establish depth of cavity required and fix Speedline SWL60 Perimeter Track at maximum 600mm centres, SWL60 should be positioned so that the longest leg is facing the room.

Mark vertical lines at maximum 600mm centres to correspond with position of Speedline SWL507 Wall Liner centres. Divide vertical lines by 800mm to indicate fixing point for AWL03B, AWL04B or AWL08B Fixing Brackets. Drill a 6mm diameter hole and fix brackets into position using Speedline Metal Nail In fixings.

Cut SWL507 Wall Liner to length and friction fit into track. To extend SWL507 Wall Liner use AWL05B Wall Liner Connectors.

Fix each leg of bracket to SWL507 Wall Liner using Speedline Wafer Head Screws. Should leg of bracket extend beyond face of liner, simply fold back to provide a flush surface.

Fix board lining at maximum 300mm centres to all perimeters and intermediate wall liner sections using the appropriate length of Speedline Drywall Screw. Refer to table on page 23 for board thickness/fixing length combination.

Fixtures

Medium to heavy fixtures such as heating units, radiators, shelving and cupboards can be supported by a plywood pattress incorporated within the framing cavity (refer to construction details). For all other types of fixtures please contact enquiries@speedlinedrywall.co.uk for further assistance.

SPEEDLINE WALL LINER SYSTEM

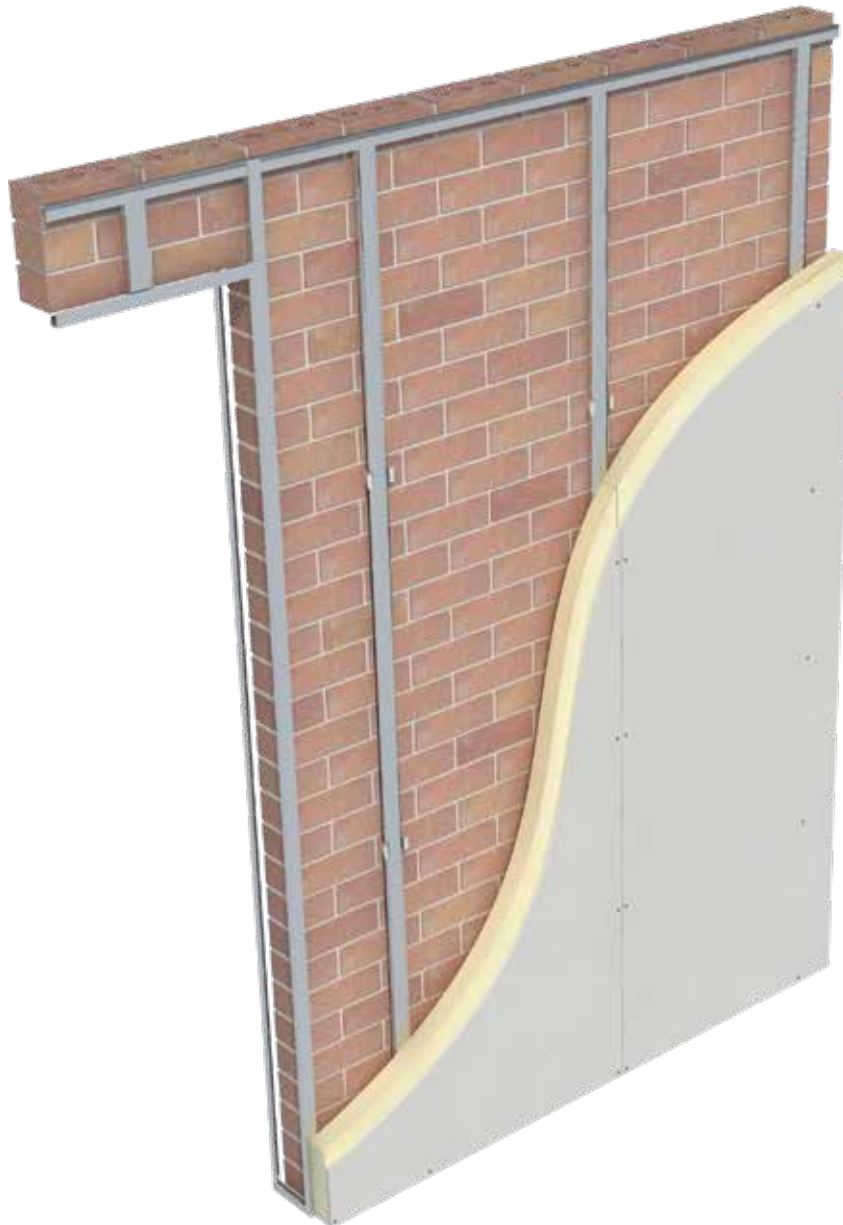
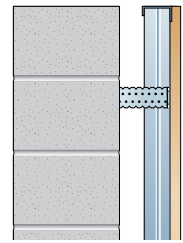

Speedline Thermal Laminate Boards provides a thermal insulation solution in a single application and is suitable for use with Speedline Wall Liner System.

Speedline Thermal Laminate Boards in conjunction with Speedline Wall Liner System will assist you to meet or upgrade to the current Building Regulations and avoid the risk of condensation. Locating the thermal insulation layer on the internal side of the structure is more responsive to heating conditions resulting in the ambient internal temperature of a building becoming comfortable quicker whilst reducing thermal bridging through the structure.

The table below provides details on U-Values (W/m^2K) achievable with the stated board thickness and masonry background. Please contact enquiries@speedlinedrywall.co.uk for further assistance and U-Value calculations.

Speedline Masonry Walls - Mechanical fix onto Speedline Wall Liner System

Speedline PIR Thermal Laminate Board results

Board Thickness	Thermal Resistance (M^2K/W)	U-Value (W/m^2K)
62.5mm	2.31	0.34
72.5mm	2.79	0.29
82.5mm	3.30	0.26
92.5mm	3.70	0.23

The above U Value calculation is based upon a solid 215mm masonry wall with Speedline PIR Thermal Laminate Board being mechanically fixed into Speedline Wall Liner System.

WALL LINING SYSTEMS

SPEEDLINE WALL LINER SYSTEM

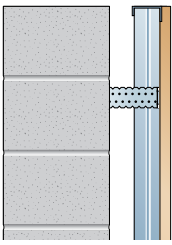

WALL LINER

HEAD, FLOOR & BRACKET

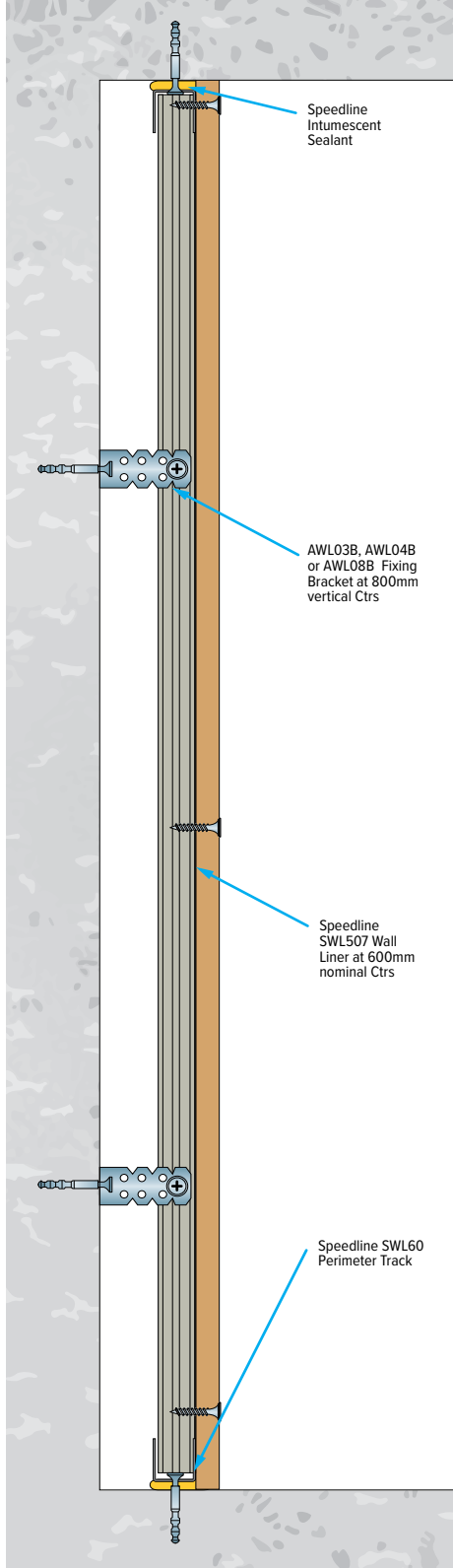

WALL LINER

EXTERNAL CORNER

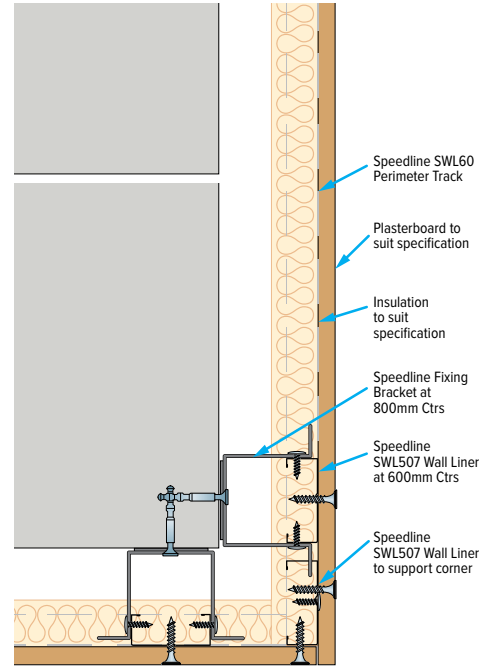

WALL LINER

INTERNAL CORNER

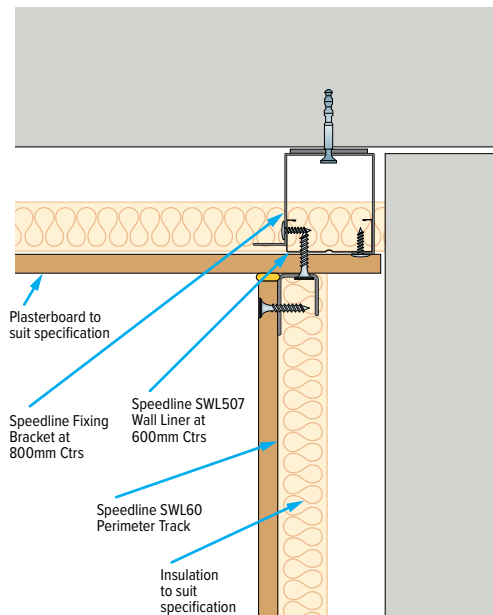

SPEEDLINE WALL LINER SYSTEM

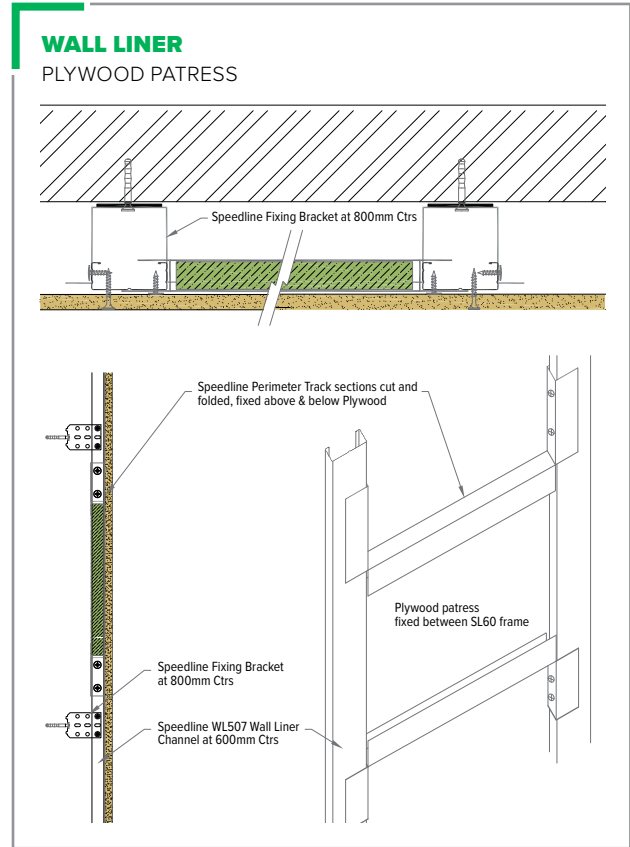
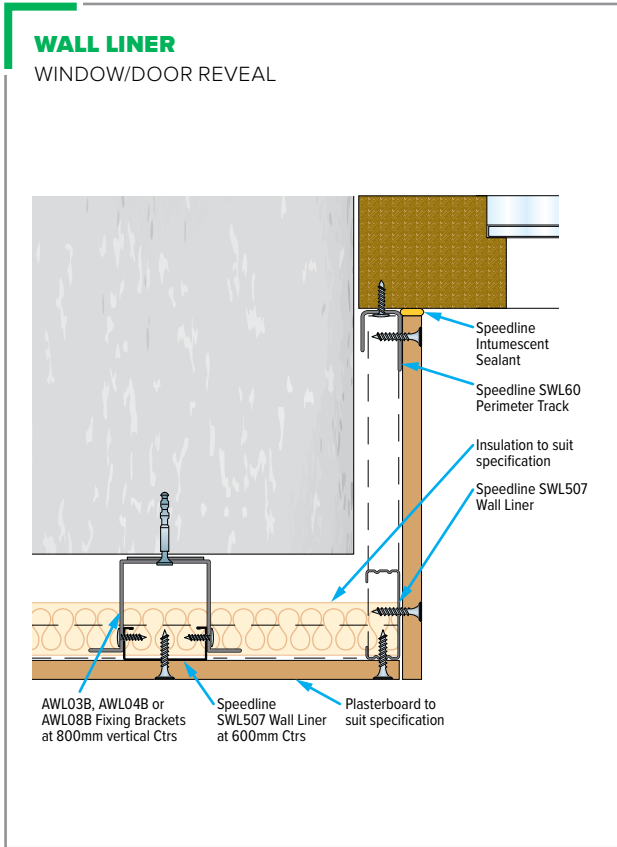
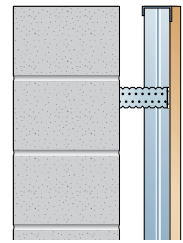

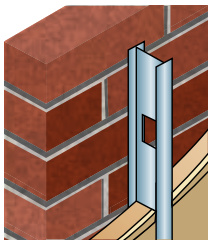

WALL LINING SYSTEMS

SPEEDLINE INDEPENDENT WALL LINING SYSTEM

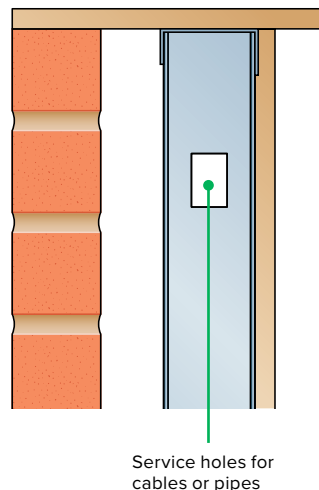
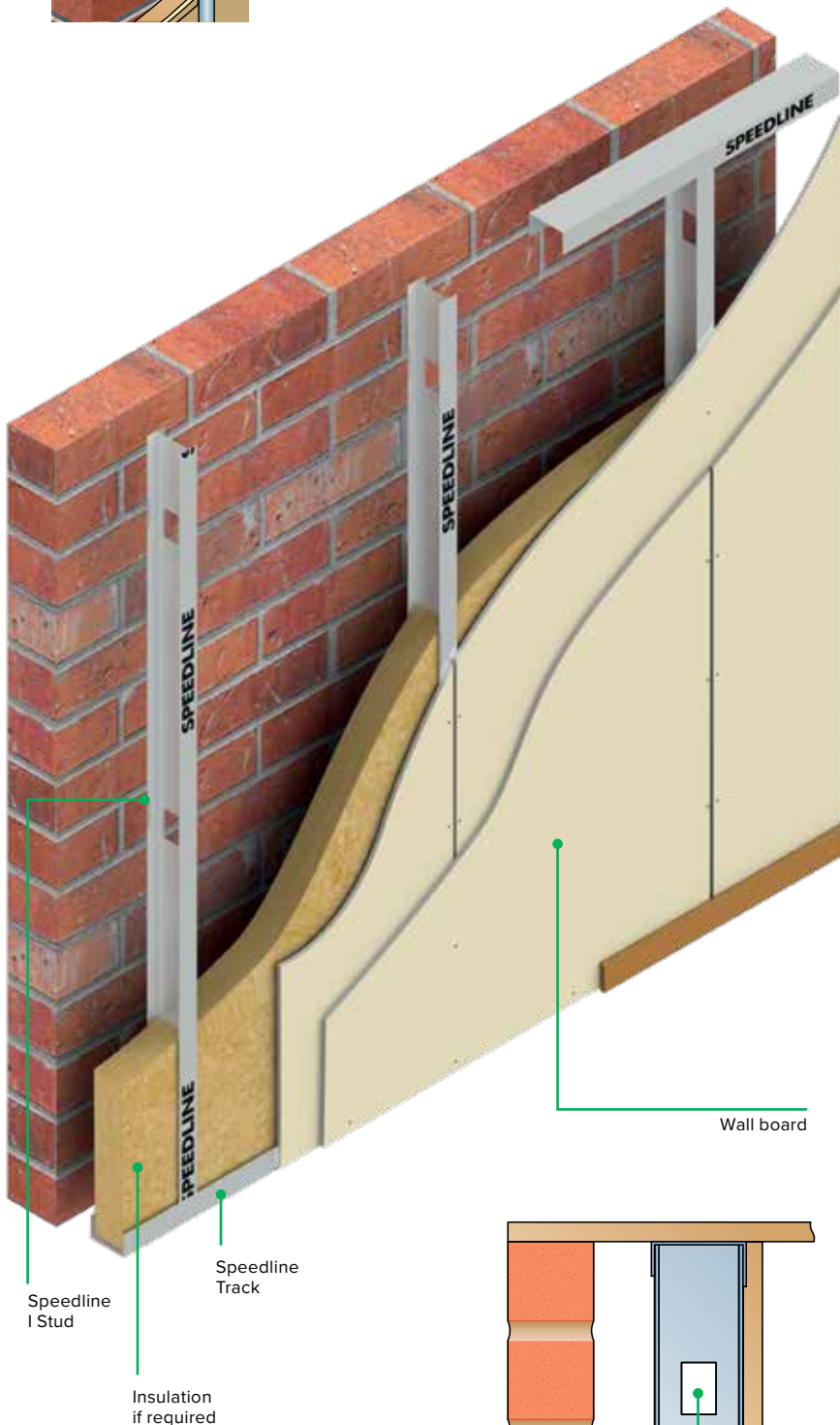

Benefits

- Speedline Independent Wall Lining System provides a cavity for services to be routed through.
- Speedline Independent Wall Lining System offer a range of I stud widths of 50mm, 60mm, 70mm, 92mm & 146mm to achieve a wide range of height requirements up to 7.2 metres without any additional bracing to structure.
- Speedline systems are suitable for fixing all types of plasterboard including Speedline Thermal Laminate Boards.
- Independent of structure although it can be braced back for greater heights.
- Speedline stud holds insulation to improve levels of sound and thermal insulation.

Speedline Independent Wall Lining System has been designed to provide a lining solution that is totally free of the substrate. It can be used where other lining solutions such as plaster or direct bond are unsuitable.

Speedline I Studs are friction fitted within Speedline tracks at nominal 600mm centres. Insulation can be incorporated within the framework cavity to improve sound and thermal insulation along with the correct type of gypsum plasterboard.

Fix board lining at maximum 300mm centres to all perimeters and intermediate I studs using the appropriate length of Speedline Drywall Screw. Refer to table on page 23 for board thickness/fixing length combination.

Prior to installing Speedline Independent Wall Lining System within older buildings, ensure the substrate is sound and free of any damp.

Please contact enquiries@speedlinedrywall.co.uk for further assistance.

Sectors

- Residential
- Healthcare
- Education
- Commercial
- Retail
- Student Accommodation
- RMI

SPEEDLINE INDEPENDENT WALL LINING SYSTEM

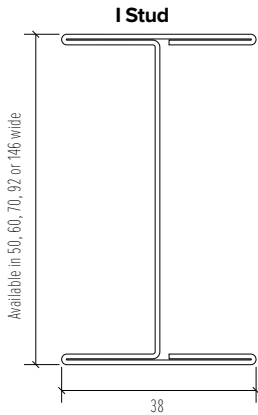
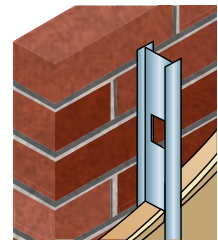

SPEEDLINE I STUD

Product Code	Width (mm)	Nominal Gauge (mm)	Flange Dimensions (mm)	Stock Lengths (Metre)	Weight per Length (Kgs)
PI50	50mm I Stud	0.5	38	2.70	1.98
				3.00	2.20
				3.60	2.64
PI60	60mm I Stud	0.5	38	2.70	2.08
				3.00	2.31
				3.60	2.77
PI70	70mm I Stud	0.7	38	4.20	3.23
				3.00	2.92
				3.60	3.50
PI92	92mm I Stud	0.8	38	4.20	4.09
				3.00	2.92
				3.60	3.50
PI146	146mm I Stud	0.8	38	6.00	8.63
				3.60	5.18
				6.00	10.67

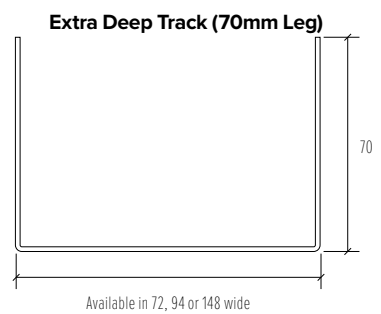
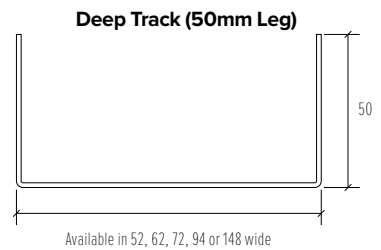
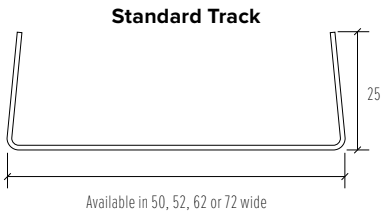

SPEEDLINE TRACKS

Product Code	Width (mm)	Nominal Gauge (mm)	Flange Dimensions (mm)	Stock Lengths (Metre)	Weight per Length (Kgs)
SPT52	52mm Track	0.5	25	3.00	1.13
PT62	62mm Track	0.5	25	3.00	1.25
SPT72	72mm Track	0.5	25	3.00	1.37
SPT94	94mm Track	0.5	32	3.00	1.79
SPT148	148mm Track	0.5	32	3.00	2.40
PEDT62	62mm Deep Track	0.5	50	3.00	1.79
SPEDT72	72mm Deep Track	0.5	50	3.00	1.91
SPEDT94	94mm Deep Track	0.5	50	3.00	2.16
SPDT148	148mm Deep Track	0.5	50	3.00	2.80
SPXDT72	72mm Extra Deep Track	0.7	70	3.00	3.32
SPXDT94	94mm Extra Deep Track	0.7	70	3.00	3.69
SPXDT148	148mm Extra Deep Track	0.7	70	3.00	4.58



SPEEDLINE FLAT BRACING STRIP & PARTITION BRACE

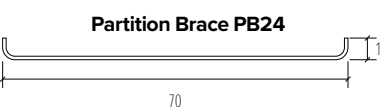
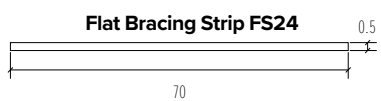

Product Code	Product Description	Nominal Gauge (mm)	Height (mm)	Stock Lengths (Metre)	Weight per Length (Kgs)
FS24	Flat Bracing Strip	0.5		2.40	0.66
PB24	Partition Brace	0.7	10	2.40	1.09



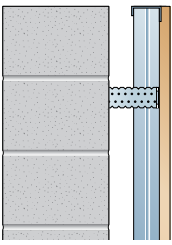

WALL LINING SYSTEMS

SPEEDLINE INDEPENDENT WALL LINING SYSTEM

Speedline Independent Wall Lining maximum heights I Stud at 600mm centres

Maximum Height Table		I Stud Width (mm)	Maximum Height (m)	Nominal Weight (kg/m ²)	Nominal Width (mm)	
	100mm brickwork and I Studs. One layer of 12.5mm standard wallboard 25mm Glass mineral wool.	MD	50	2.4*	10	190
			60	2.7*	11	200
			70	3.0*	11	210
			92	4.5*	12	230
	100mm brickwork and I Studs. Two layers of 12.5mm standard wallboard 25mm Glass mineral wool.	SD	50	2.7*	19	203
			60	3.3*	20	213
			70	3.9*	20	223
			92	5.4*	21	243
			146	7.2*	21	299

*Denotes maximum unbraced height for further assistance on reduced stud centres and bracing back to structure, please contact enquires@speedlinedrywall.co.uk

Splicing Speedline I Studs

Speedline I studs can be spliced together to create longer lengths using a 600mm length of the appropriate sized Speedline Deep Track and fixed with four Speedline Wafer Head Screws to each flange (see detail below).

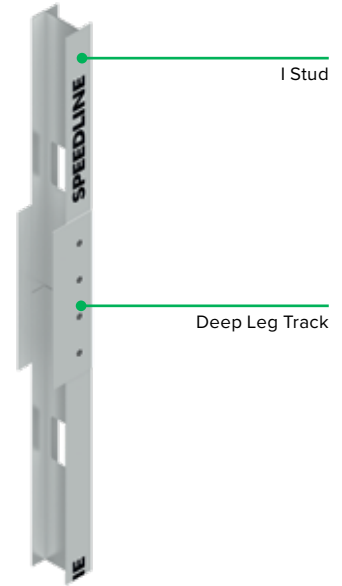

I STUD WALL LINING

HEAD AND FLOOR

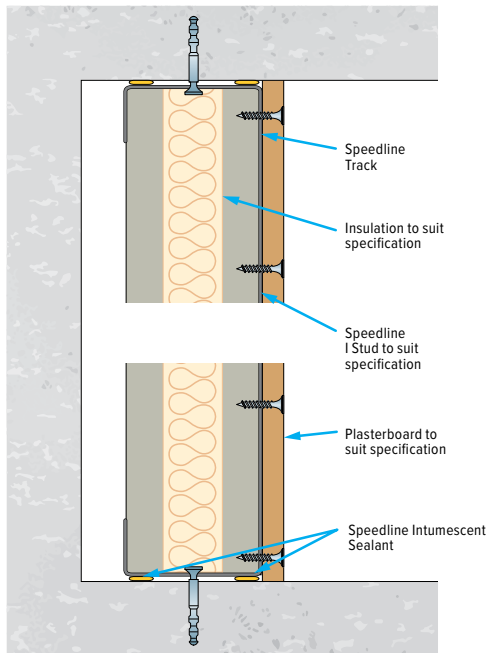

I STUD WALL LINING

DEFLECTION HEAD

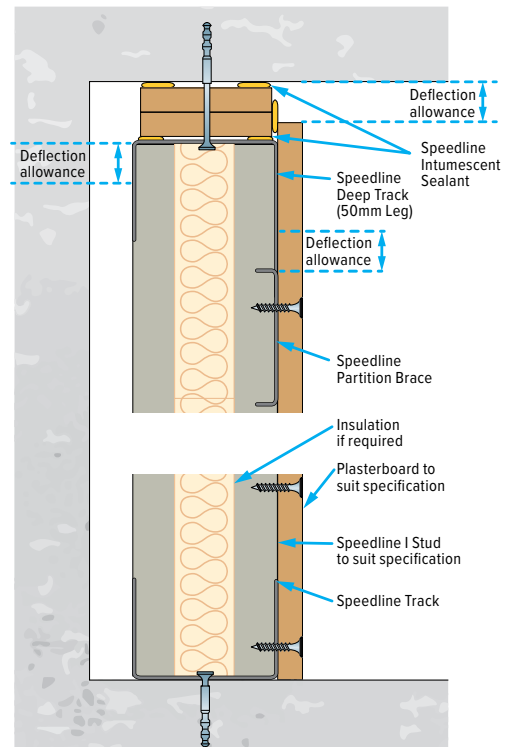

SPEEDLINE INDEPENDENT WALL LINING SYSTEM

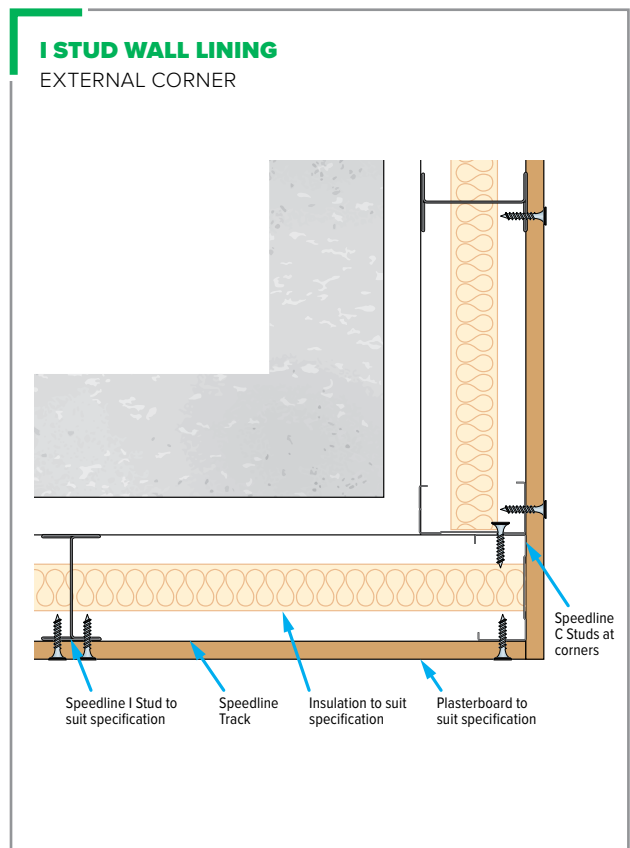
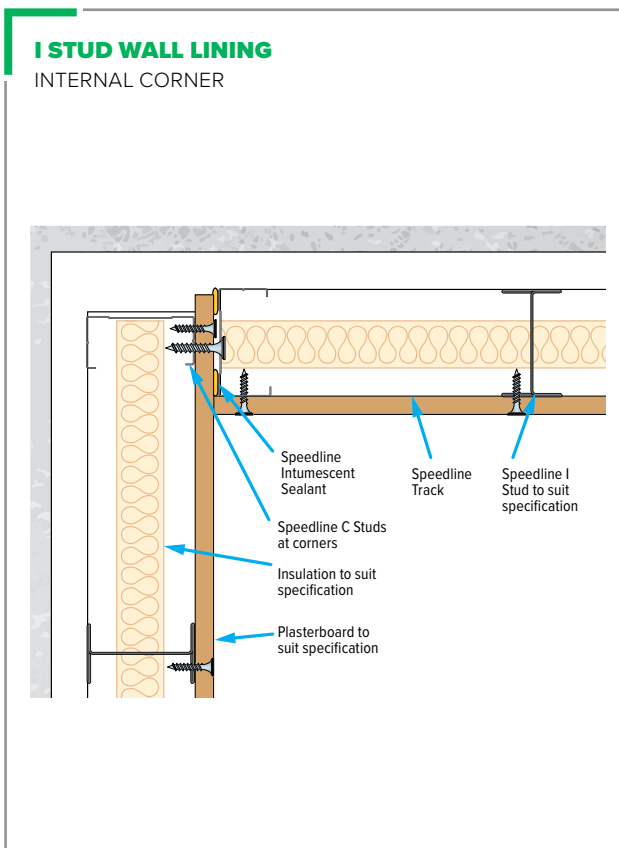
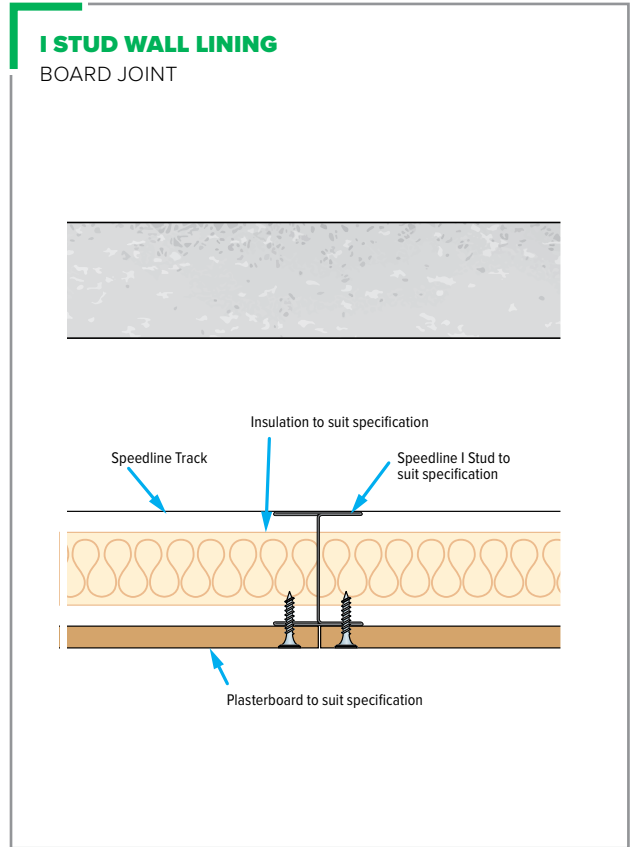
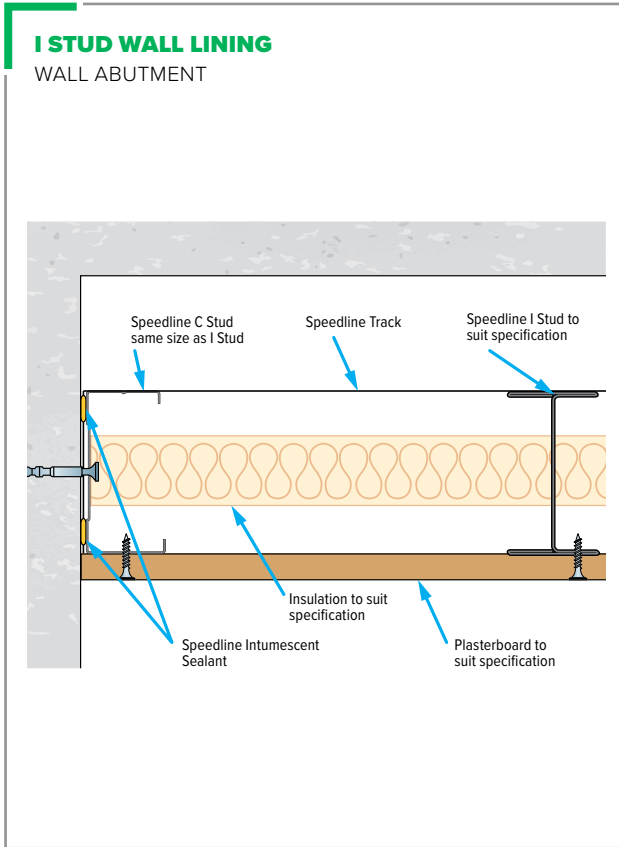
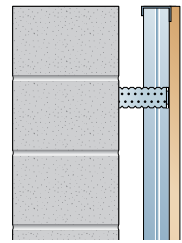

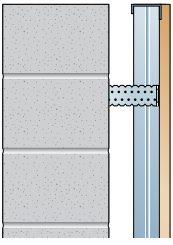

WALL LINING SYSTEMS

SPEEDLINE DIRECT BOND SYSTEM

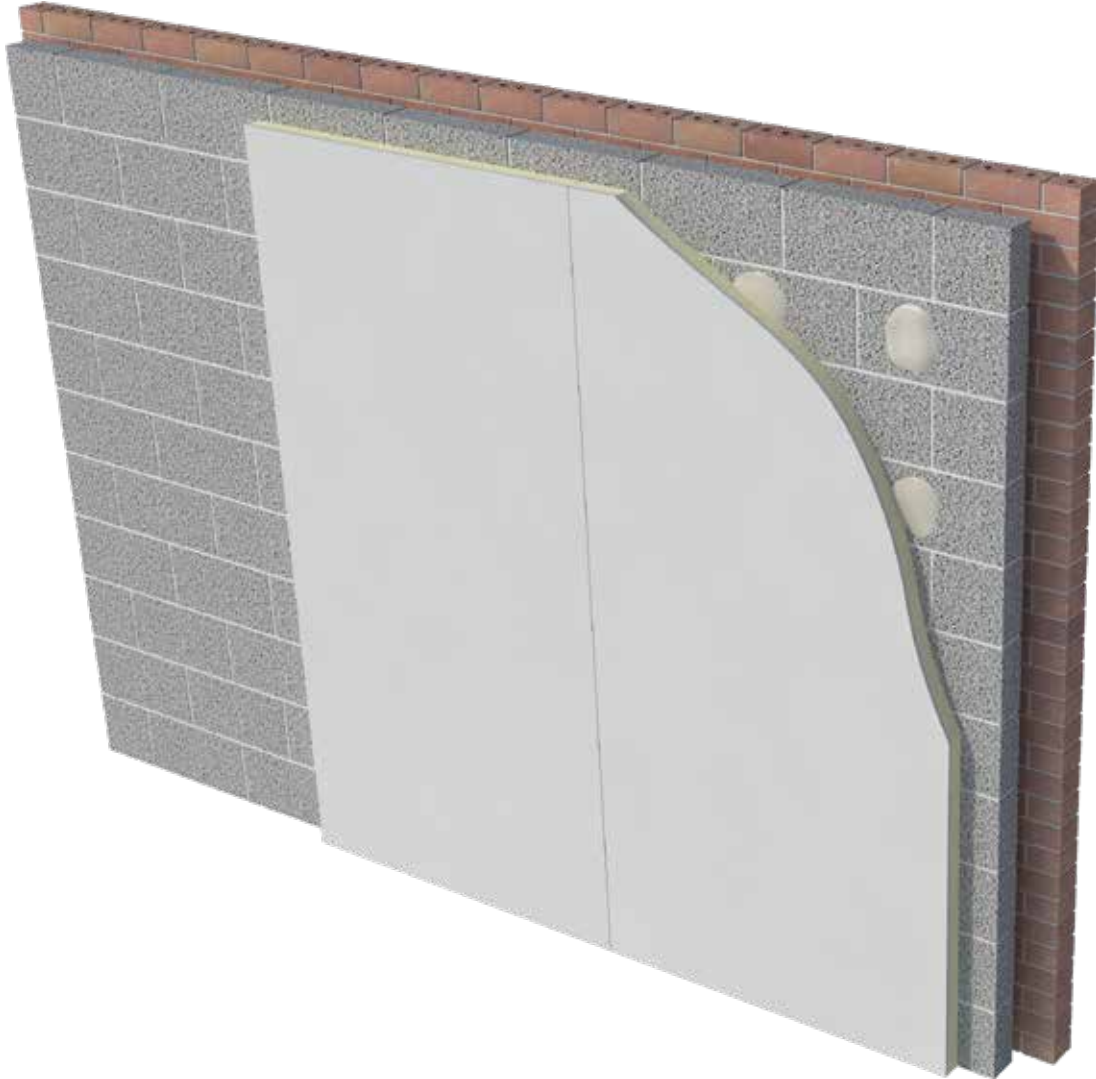

Benefits

- Minimal loss of room space due to a typical cavity space of between 10mm and 25mm Maximum.
- Small surface defects can be hidden within the cavity formed by Drywall Adhesive dabs.
- Services can be incorporated behind the plasterboard, which reduces level of chasing out. (All Electrical & Plumbing guides should be adhered to).
- Speedline Thermal Laminate Boards can be used to enhance thermal performance (see table on page 108 for further details).

Sectors

- Residential
- Healthcare
- Education
- Commercial
- Retail
- Student Accommodation
- RMI

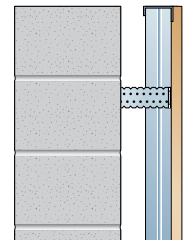

Speedline Direct Bond System

A suitable Drywall Adhesive will fix a wide range of gypsum plasterboards to most masonry backgrounds. The adhesive installation instructions should be followed while ensuring the masonry background is completely dry and free of contaminants. Additional Speedline Nylon Hammer In Screws should be used to prevent early collapse of the board in the event of a fire. All perimeter joint locations should be sealed with Speedline Intumescent Sealant to achieve an airtight seal.

If considering using Speedline Direct Bond System onto a solid masonry wall then consideration must be given towards the condition of the wall and measures taken to ensure the external wall is fully sealed/waterproof to prevent moisture penetration from occurring. Remedial work should be undertaken to remove dampness before installation of the internal wall insulation. If there is any doubt about the water tightness of a solid wall (there may be with 'half' brick walls), the external surface of the wall would need to be sealed with a suitable sealer. The existing structure should be surveyed to ensure the construction can support the weight of the internal wall system, ancillary items and any post - installation fittings.

Drywall Adhesive is not suitable for applying foil backed plasterboards; this type of board should only be mechanically fixed onto a framing solution such as Speedline Wall Liner System (see pages 96-101).

Boards should only be applied to a maximum height of 3 metres whilst small rips should be avoided.

Speedline Thermal Laminate boards (PIR and Phenolic) can be adhered using Drywall Adhesive, but will require additional mechanical fixing using Speedline Nylon Hammer Screws to ensure board stays in place in a fire situation. Use two fixings per board positioned at mid-height within the tapered edge, fixings should be installed after the dabs have set.

For further assistance and advice on the use of Speedline Direct Bond System, please contact

enquiries@speedlinedrywall.co.uk

Preparation

Linings can be direct fixed to low, medium, and high suction masonry, pre-cast and in-situ concrete, ensuring all release agents, contaminants and dust have been suitably treated or removed. A suitable, proprietary bonding agent should be used when applying Drywall Adhesive onto concrete substrates, bonding agent to be applied in bands to correspond with dab centres.

Ensure all air paths & gaps in substrate are sealed, particularly at corners & junctions. Any perpendicular joints in block work should be filled to improve acoustic performance and heat loss.

Background should be checked for alignment and allowance for boards to pass over high spots on the masonry.

Mark guidelines on the soffit and floor, allowing for irregularities and establishing the new plumb wall plane.

Work out the position of the first board application and mark wall accordingly, allowing for board rips of less than 300mm to be eliminated.

Perimeter of Room

When installing boards a continuous band of Drywall Adhesive should be applied around the wall perimeter, at window/door openings & sockets, to improve the airtightness and reduce the effects of cold convection currents. This is particularly important with Speedline Thermal Laminate boards as it may reduce the performance of the wall construction. (Continuous bands should be applied as each board is being fixed).

If applied to an exterior wall, any Interior partitions abutting the direct bond system should be fitted first and the lining taken up to the plasterboard faces. This will aid & reduce flanking transmissions.

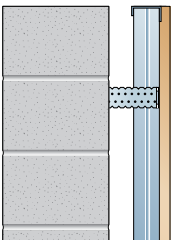

WALL LINING SYSTEMS

SPEEDLINE DIRECT BOND SYSTEM

Direct Bonding Dabs within field of plasterboards

Drywall Adhesive dab should be 250mm long and between 50mm & 75mm wide with a minimum dab thickness of 10mm and up to 25mm thick. Apply enough adhesive for one board at a time to give a minimum area of contact between board and substrate of 20%. Refer to table below for dab centres in relation to board thickness and width.

Once Drywall Adhesive has been applied, offer up the plasterboard and press firmly into place. Ensure board is in a plumb position and not resting on the floor, offcuts of board can be used as packing pieces, remove once dabs have set.

Speedline Thermal Laminate Boards require secondary mechanical fixing using two Speedline Nylon Hammer In Screws per board, positioned at mid-height within the tapered edge. Fixings should be of a sufficient length to penetrate through board, dab and into the background by at least 25mm. Fixings to be installed once the dabs have set.

Adhesive dab centres for gypsum plasterboards and Speedline Thermal Laminate Boards

Thickness/ Type of Board	Width (mm)	Adhesive Centres (mm)	Rows of dabs per board
9.5mm	900	450	3
9.5mm	1200	400	4
12.5mm	1200	600	3
All Laminates	1200	600	3

General Applications

Speedline Direct Bond System must be installed in accordance with Speedline recommendations and the recommendations of BS 8212:1995 and BS 8000: Part 8:1994.

Speedline Thermal Solutions

The table below provides details on U-Values (W/m^2K) achievable with the stated board thickness and masonry background. Please contact enquiries@speedlinedrywall.co.uk for further assistance and U-Value calculations.

Masonry Cavity Wall

Speedline PIR Thermal Laminate Board results

Board Thickness	Thermal Resistance (m^2K/W)	U-Value (W/m^2K)
62.5mm	2.31	0.30
72.5mm	2.79	0.26
82.5mm	3.30	0.23
92.5mm	3.70	0.21

The above U Value calculation is based upon a masonry cavity wall (103mm facing brick – 50mm clear cavity – 100mm lightweight blockwork 0.22 W/mK) with Speedline PIR Thermal Laminate Board being directly bonded to the internal surface with Speedline Drywall Adhesive.